



HENDRIKX CONCRETE PTY LTD

417 PRINCES HIGHWAY, OFFICER, VIC 3809

ABN: 12 067 076 751 ACN: 067 076 751

TEL: (03) 5943 2321 FAX: (03) 5943 1221

EMAIL: sales@hendrixxconcrete.com.au

WEBSITE: www.hendrixxconcrete.com.au

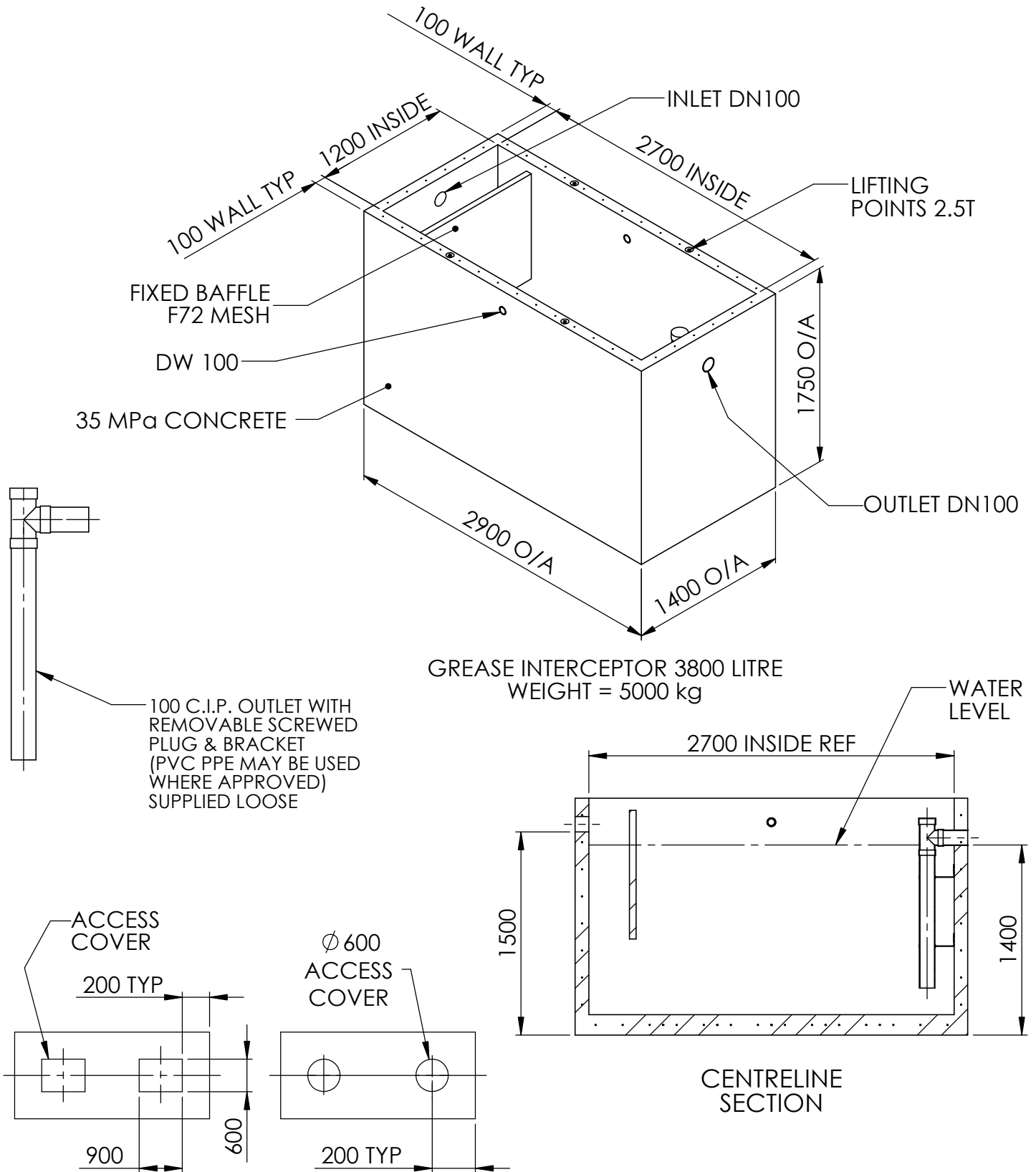

NOTES:

1. DO NOT SCALE.
2. SLIGHT TAPER ON CONCRETE UNITS.
3. MEASUREMENT IN MILLIMETRES.

LIDS:

AVAILABLE IN CONCRETE, 2900 x 1400 mm
LIGHT = 150 THK, HEAVY = 250 THK

Drawing Number:

13-HDC-074-I

Title:

GREASE INTERCEPTOR 3800L - INFORMATION

Drawn:

EV

Date:

14.07.14

Rev:

3