



HENDRIKX CONCRETE PTY LTD

417 PRINCES HIGHWAY, OFFICER, VIC 3809

ABN: 12 067 076 751 ACN: 067 076 751

TEL: (03) 5943 2321 FAX: (03) 5943 1221

EMAIL: sales@hendrixxconcrete.com.au

WEBSITE: www.hendrixxconcrete.com.au

WATER TANK 3600 Litre HOLDING TANK PUMP PIT

Weight = 3500 kg

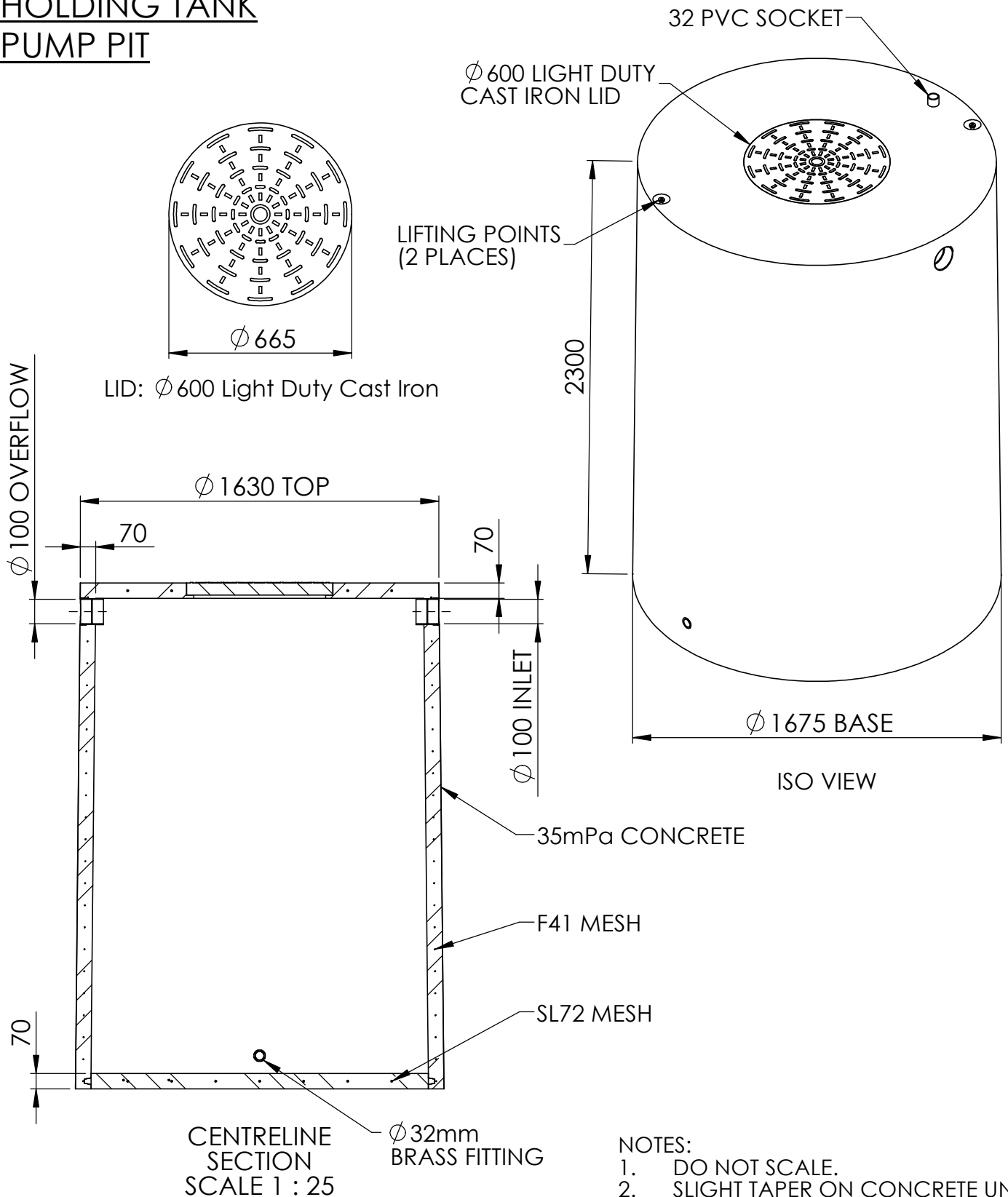

| | | | | |
|--|---|---------------------|--------------------------|------------------|
| Drawing Number: 13-HDC-101-I | Title: ROUND WATER TANK 3600L - INFORMATION | Drawn: MM | Date: 24.02.17 | Rev: 2 |
|--|---|---------------------|--------------------------|------------------|