



# HENDRIKX CONCRETE PTY LTD

417 PRINCES HIGHWAY, OFFICER, VIC 3809

ABN: 12 067 076 751 ACN: 067 076 751

TEL: (03) 5943 2321 FAX: (03) 5943 1221

EMAIL: sales@hendrikkxconcrete.com.au

WEBSITE: www.hendrikkxconcrete.com.au

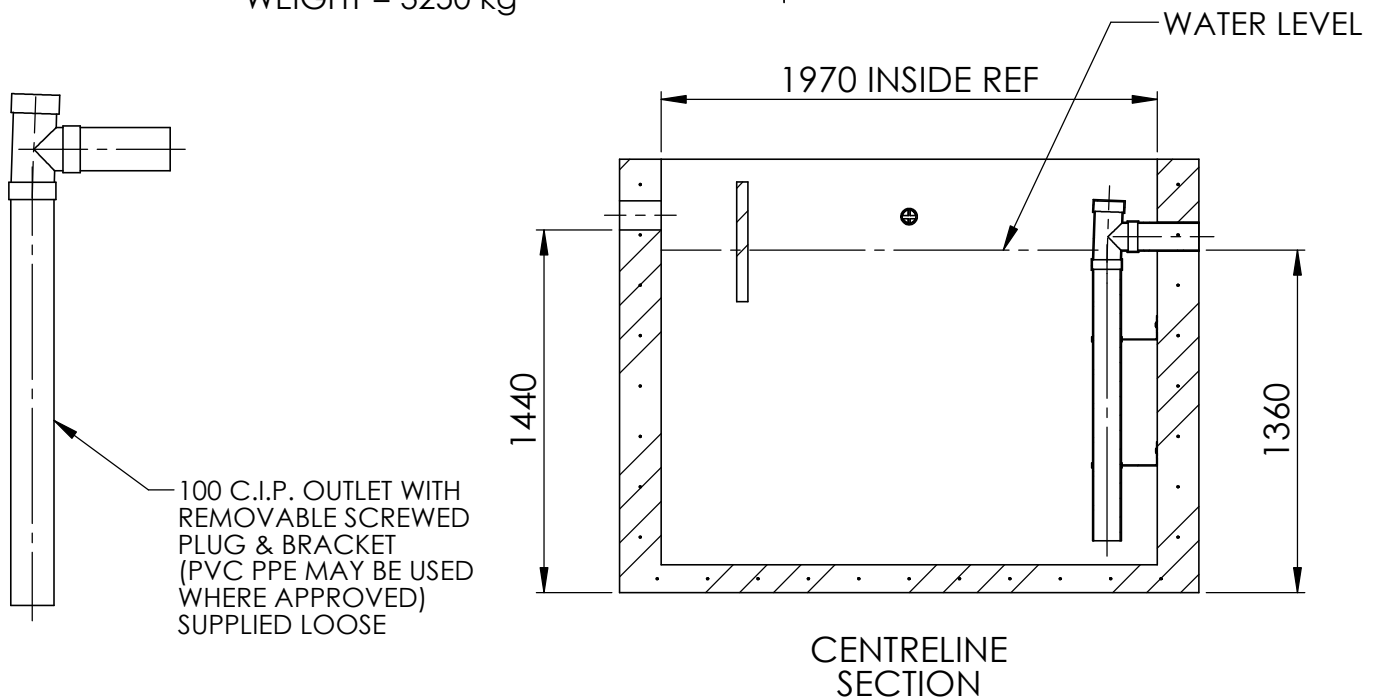
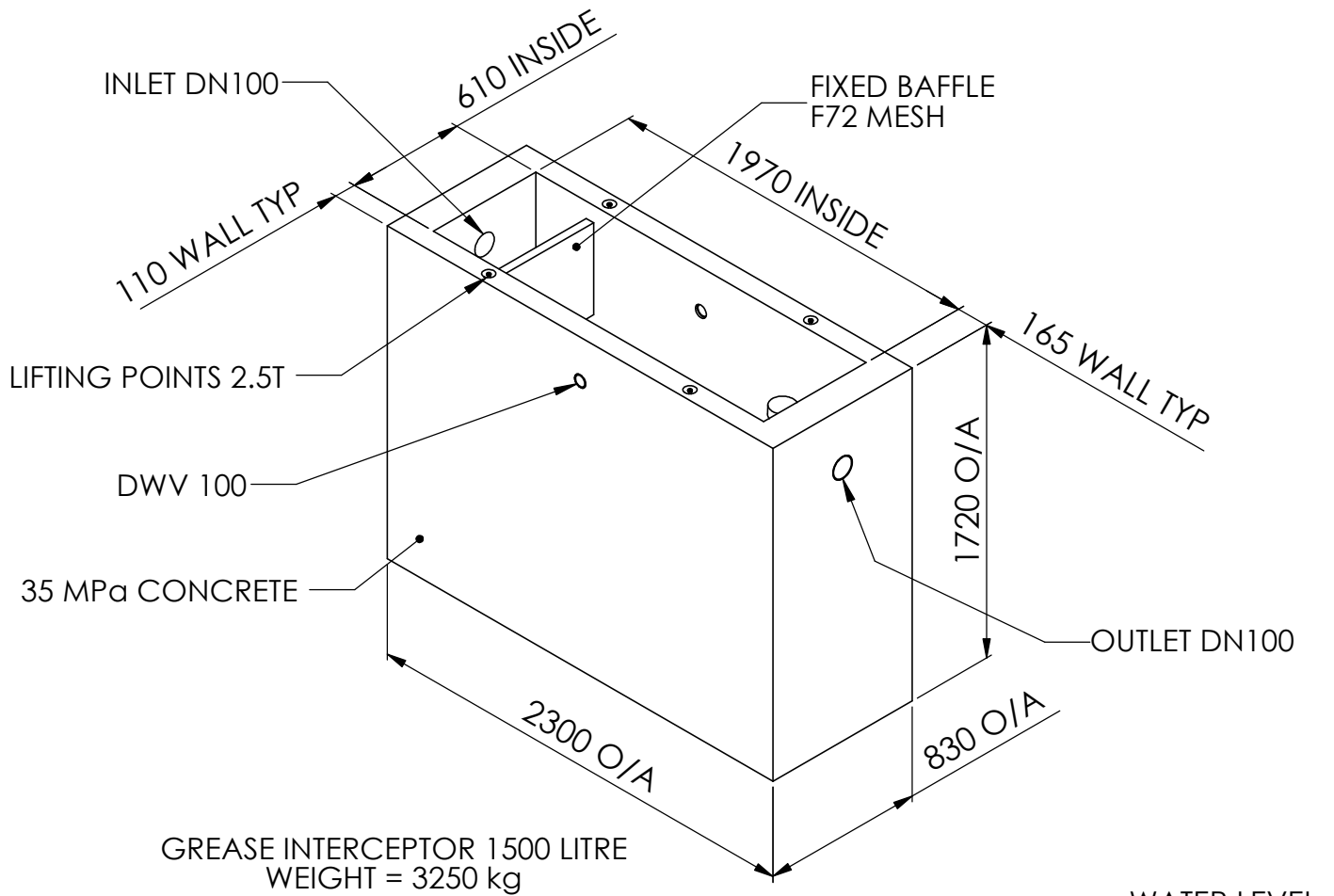

**NOTES:**

1. DO NOT SCALE.
2. SLIGHT TAPER ON CONCRETE UNITS.
3. MEASUREMENT IN MILLIMETRES.

LIDS:  
AVAILABLE IN CAST IRON  
LIGHT = 50 THK, HEAVY = 95 THK

Drawing Number: <b>13-HDC-072-I</b>	Title: <b>GREASE INTERCEPTOR 1500L - INFORMATION</b>	Drawn: <b>EV</b>	Date: <b>14.07.14</b>	Rev: <b>3</b>
--	---	---------------------	--------------------------	------------------