



# HENDRIKX CONCRETE PTY LTD

417 PRINCES HIGHWAY, OFFICER, VIC 3809

ABN: 12 067 076 751 ACN: 067 076 751

TEL: (03) 5943 2321 FAX: (03) 5943 1221

EMAIL: sales@hendrixxconcrete.com.au

WEBSITE: www.hendrixxconcrete.com.au

## WATER TANK 5200 Litre HOLDING TANK PUMP PIT

Weight = 4500 kg

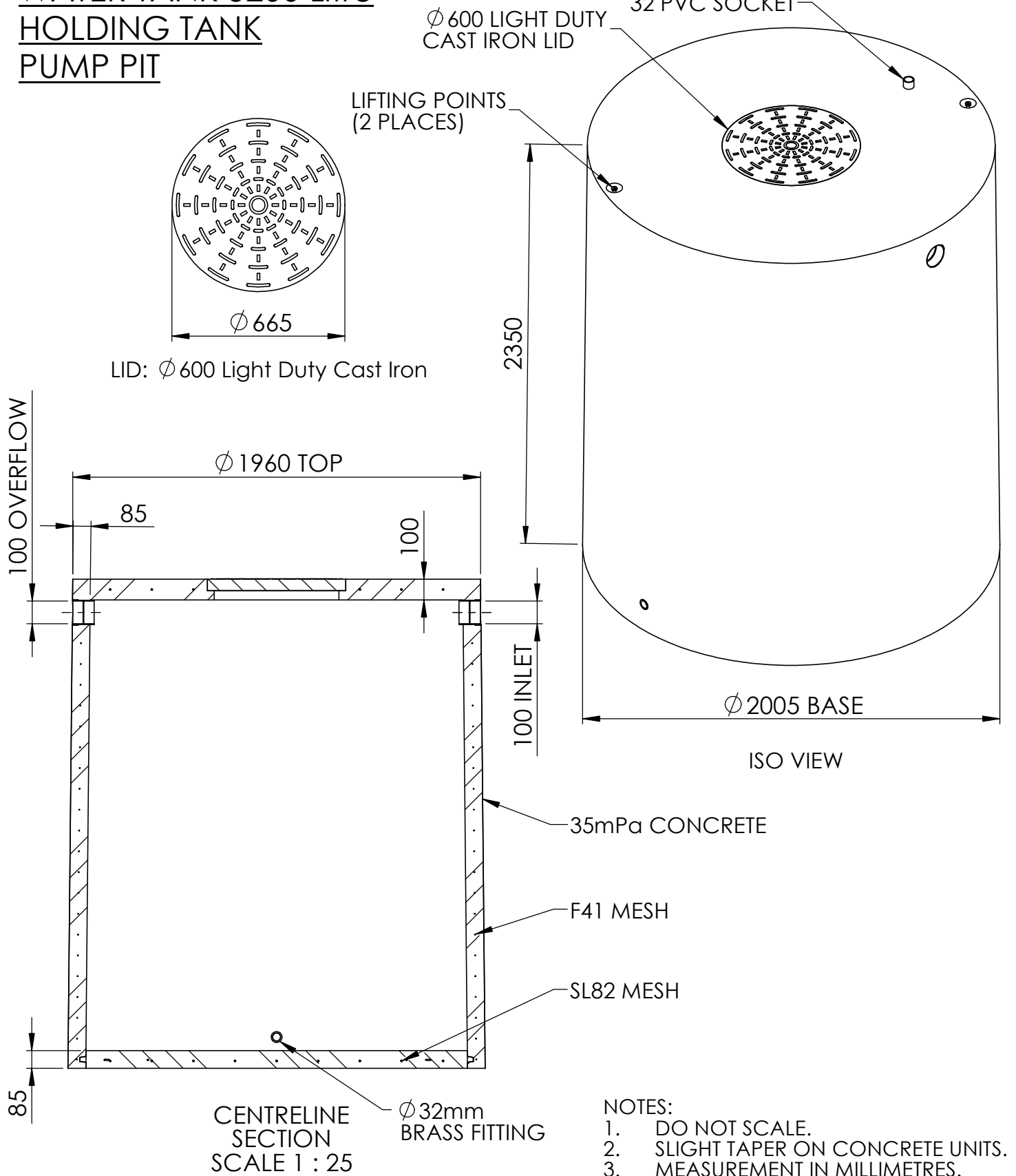

Drawing Number: <b>13-HDC-102-I</b>	Title: <b>ROUND WATER TANK 5200L - INFORMATION</b>	Drawn: <b>MM</b>	Date: <b>24.02.17</b>	Rev: <b>2</b>
----------------------------------------	-------------------------------------------------------	---------------------	--------------------------	------------------